

ADDENDUM 3

DATE: January 25, 2017
PROJECT: UCT Vertical Expansion
RFP NO: 744-R1709
OWNER: The University of Texas Health Science Center at Houston
TO: Prospective Proposers

This Addendum forms part of and modifies Proposal Documents dated, November 17, 2016, with amendments and additions noted below.

A601 has been reissued, and is attached below. It will also be uploaded to the vault. The vault can be accessed through this link and you must use your own user name and password to access – [Click here to see Project Details.](#)

Below are some clarifications regarding the responses that were provided in Addendum 1A:

From Addendum 1A – Question 101 --

Sheet A006, east garage wall Grid A, 15 to 19 does not show any vehicle barrier but the structural drawing S110 has detail 9/S201, 10/S201, 11/S201 which indicates vehicle barrier.

- a. Provide spacing for HSS 6x6x1/4 post.
- b. Is this to be galvanized or painted?
- c. Detail 11/S01 indicates a field weld post to plate – is this acceptable to shop fabricate post to plate

Revised Response: The extent of the vehicle barrier system is shown in sheet S110 of Addendum No. 1. The steel channel vehicle barrier system shall occur along the existing Western masonry parapet wall and along the Eastern and Southern precast concrete parapet walls. Contractor to determine/estimate the length of existing parapet walls to determine and number of posts required (see response to item “a” below)

- a) Spacing of the HSS6x6x1/4 shall be max 8'-0" o.c. Post spacing may need to be adjusted to accommodate for interference w/ existing concrete framing and at the corners/ edges of the existing perimeter precast and masonry parapets.
- b) As indicated in note No. 9 of the level 6 framing plan all exposed steel shall be galvanized steel, U.N.O
- c) At contractor's discretion the ¼" closure plate shown in detail 11/S201 can be shop welded to the steel tube post. The steel tube post to baseplate connection shown in detail 10/S201 can also be shop welded to the baseplate. We recommend that all steel channel to steel tube posts connection be field welded to allow for proper field fitup.

From Addendum 1A – Question 141 --

Question response 141 states that the existing as built structural plans for the existing parking garage are to be “included in Addendum”. Please advise when these are to be provided.

These were emailed yesterday, but since the file is quite large, we will also upload them to the vault.

From Addendum 1A – Question 152 --

Question 152 requires more information to price the ramps at these locations. Is there a curb on these ramps? What type of reinforcing is required? If possible, please provide a section cut for additional information.

Response: The approximate width of the ramp is shown in Sheet S110 of Addendum No. 1. The length of the Level 6 ramp opening can be determined based on the dimensions provided (from Grids F' to L' minus the 6'3 dimension shown near the South-East corner of the ramp vehicle barrier wall). The approximate length of the ramp is to be determined/estimated by the contractor, this ramp extends from Grid F' on level 5 as shown in Plan/Det. 1/S101 up to Grid L' on Level 6 as shown in Sheet S110.

From Addendum 1A – Question 155 --

Question response 155 originally stated that this needs to be “coordinated with ARCH/MEP”, but now states that we are to “see struct vehicle barrier locations”. Please indicate where these locations are to be found or if they are required on this project. If required, please provide a detail for this protection. What is the height, width, and thickness of this plate. Is it a custom item, or is there manufacturer specifications required?

Response: There are no instances in project.

SHEETS ISSUED:

ARCHITECTURAL

A601 DOOR, OPENINGS AND FRAME TYPES

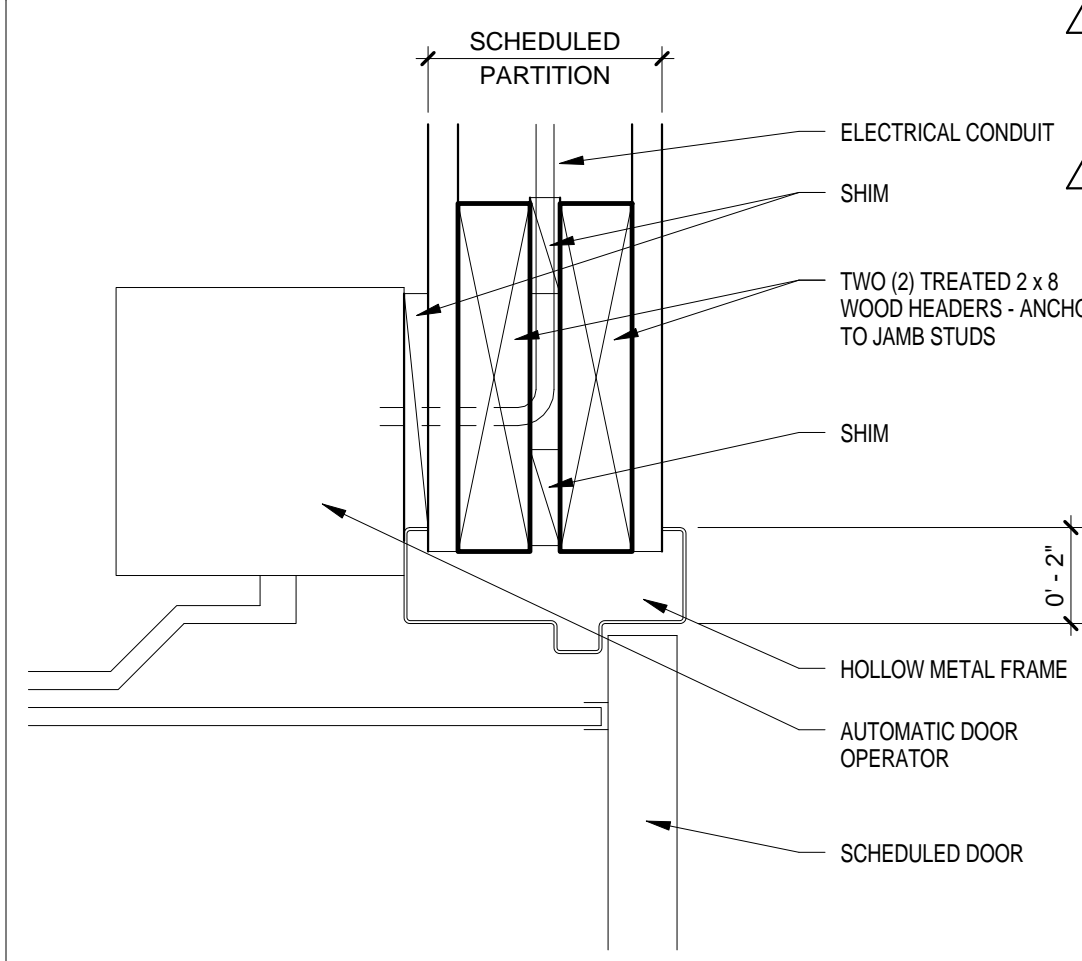

7 AUTO. DOOR HEAD

Framed Opening Schedule															
Mark	Type	Door				Frame				Rev Date	Comments	Level	Fire Rating (MIN)		
		Material	Finish	Width	Height	Type	Material	Finish	Glazing					HDW	
7T09				4'-0"	1'-0"								ROOF HATCH		
LEVEL 5															
5067	F	HM	P	3'-0"	7'-0"	1	HM	P		1				LEVEL 5	90
LEVEL 6															
6D05	F	SC	PL	3'-0"	7'-0"	1	AL	AN		108				LEVEL 6	--
6E05	F	SC	PL	3'-0"	7'-0"	1	AL	AN		108				LEVEL 6	--
6H01	UP	SC	PL	4'-0"	7'-0"	1	AL	AN		103				LEVEL 6	--
6J05	F	SC	PL	3'-0"	7'-0"	1	AL	AN		107				LEVEL 6	--
6M05	FP	SC	PL	6'-0"	7'-0"	1	AL	AN		109				LEVEL 6	--
6M06	FP	SC	PL	6'-0"	7'-0"	1	AL	AN		109				LEVEL 6	--
6S0G	F	HM	P	3'-0"	7'-0"	1	HM	P		101				LEVEL 6	90
6S0G.1	F	SC	PL	3'-0"	7'-0"	1	AL	AN		102				LEVEL 6	45
6S0GA	F	HM	P	3'-0"	7'-0"	1	HM	P		3				LEVEL 6	90
6S0L *	F	SC	PL	3'-0"	7'-0"	1	-	-		104				LEVEL 6	--
6T05	F	SC	PL	3'-0"	7'-0"	1	AL	AN		105				LEVEL 6	--
6T06	F	SC	PL	3'-0"	7'-0"	1	AL	AN		105				LEVEL 6	--
6028A	F	HM	P	3'-6"	7'-0"	1	HM	P		2				LEVEL 6	--
6028B	F	HM	P	3'-6"	7'-0"	1	HM	P		2				LEVEL 6	--
6033	F	HM	P	3'-0"	7'-6"	1	HM	P		1				LEVEL 6	90
6061	F	AL	AN	6'-4"	7'-9 1/2"	1	AL	AN		4				LEVEL 6	--
6089	F	HM	P	3'-0"	7'-0"	1	HM	P		2				LEVEL 6	--
LEVEL 7															
7D05	F	SC	PL	3'-0"	7'-0"	1	AL	AN		108				LEVEL 7	--
7E05	F	SC	PL	3'-0"	7'-0"	1	AL	AN		108				LEVEL 7	--
7H01	UP	SC	PL	4'-0"	7'-0"	1	AL	AN		103				LEVEL 7	--
7J05	F	SC	PL	3'-0"	7'-0"	1	AL	AN		107				LEVEL 7	--
7M05	FP	SC	PL	6'-0"	7'-0"	1	AL	AN		109				LEVEL 7	--
7M06	FP	SC	PL	6'-0"	7'-0"	1	AL	AN		109				LEVEL 7	--
7S0G	F	SC	PL	3'-0"	7'-0"	1	HM	P		101				LEVEL 7	90
7S0G.1	F	SC	PL	3'-0"	7'-0"	1	AL	AN		102				LEVEL 7	45
LEVEL 8															
8SOG	F	HM	P	3'-0"	7'-0"	1	HM	P		5				LEVEL 8	45
UCT LEVEL 7															
7SH1 *	F	SC	PL	3'-0"	8'-0"	1	-	-		104				UCT LEVEL 7	--
7T05	F	SC	PL	3'-0"	7'-0"	1	AL	AN		105				UCT LEVEL 7	--
7T06	F	SC	PL	3'-0"	7'-0"	1	AL	AN		106				UCT LEVEL 7	--

GENERAL NOTES

- A. RE-USE SALVAGED DOOR SLABS AND DOOR HARDWARE - TYP
- B. PROVIDE NEW DOOR SLABS AND DOOR HARDWARE TO MATCH EXISTING AS REQUIRED FOR INCREASED QUANTITIES
- C. PROVIDE NEW DOOR HARDWARE TO MATCH EXISTING AS REQUIRED FOR CHANGE IN FUNCTION
- D. PROVIDE NEW CORES FOR ALL OPENINGS: W/ THREE KEYS PER CORE. SEE SPECS FOR KEYING AND CYLINDERS
- E. MG-1 GLASS AT INTERIOR WINDOW FRAMES AND DOOR LITES - TYP - U.N.O.
- F. PROVIDE KEY LOCK TO EXTERIOR SECURITY GATE. RE: BA4008.

WHR ARCHITECTS

1111 Louisiana 26th Floor
Houston, TX 77002
T 713 665 5665 whrarchitects.com

REVISIONS		
NO.	DATE	DESCRIPTION
1	01-13-17	ADDENDUM #1
2	01-23-17	ADDENDUM #2
3	01-24-17	ADDENDUM #3

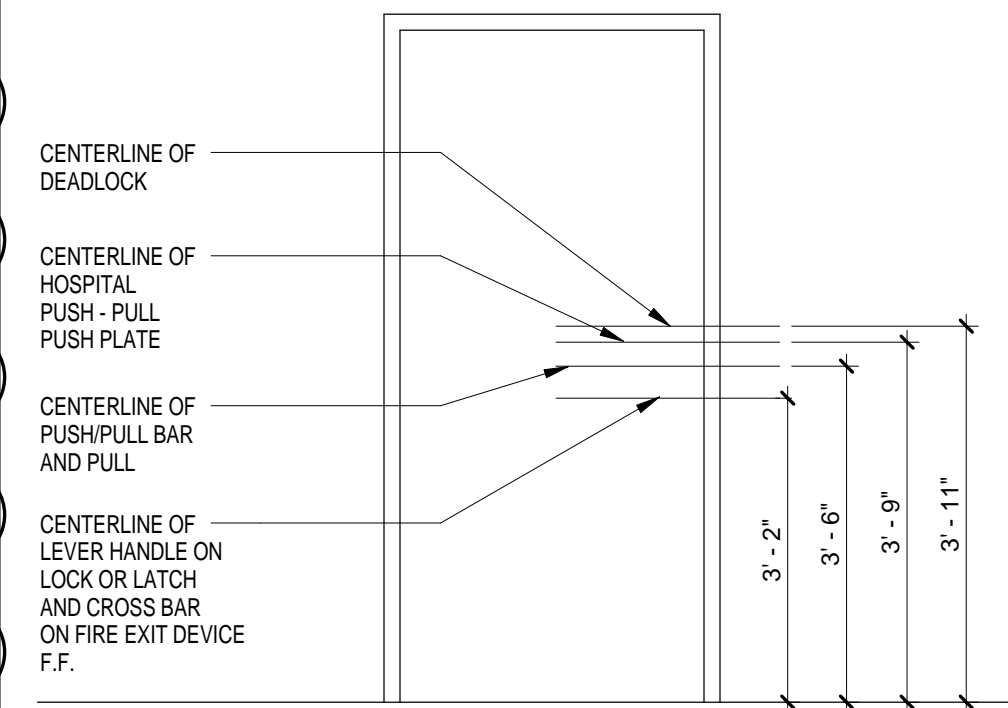

DOOR HARDWARE LOCATIONS
(ILLUSTRATED HARDWARE LOCATIONS TAKE PRECEDENCE OVER REFERENCED STANDARDS)

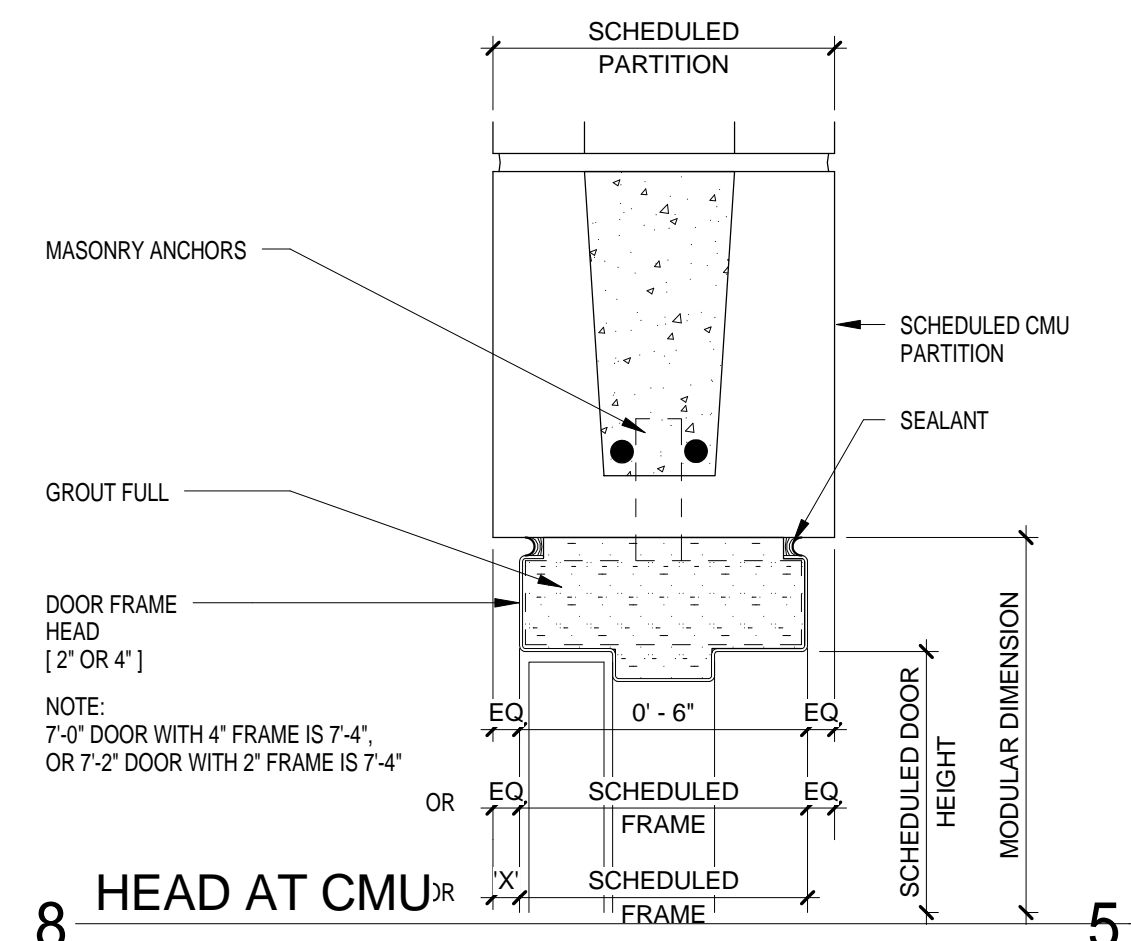

8 HEAD AT CMU

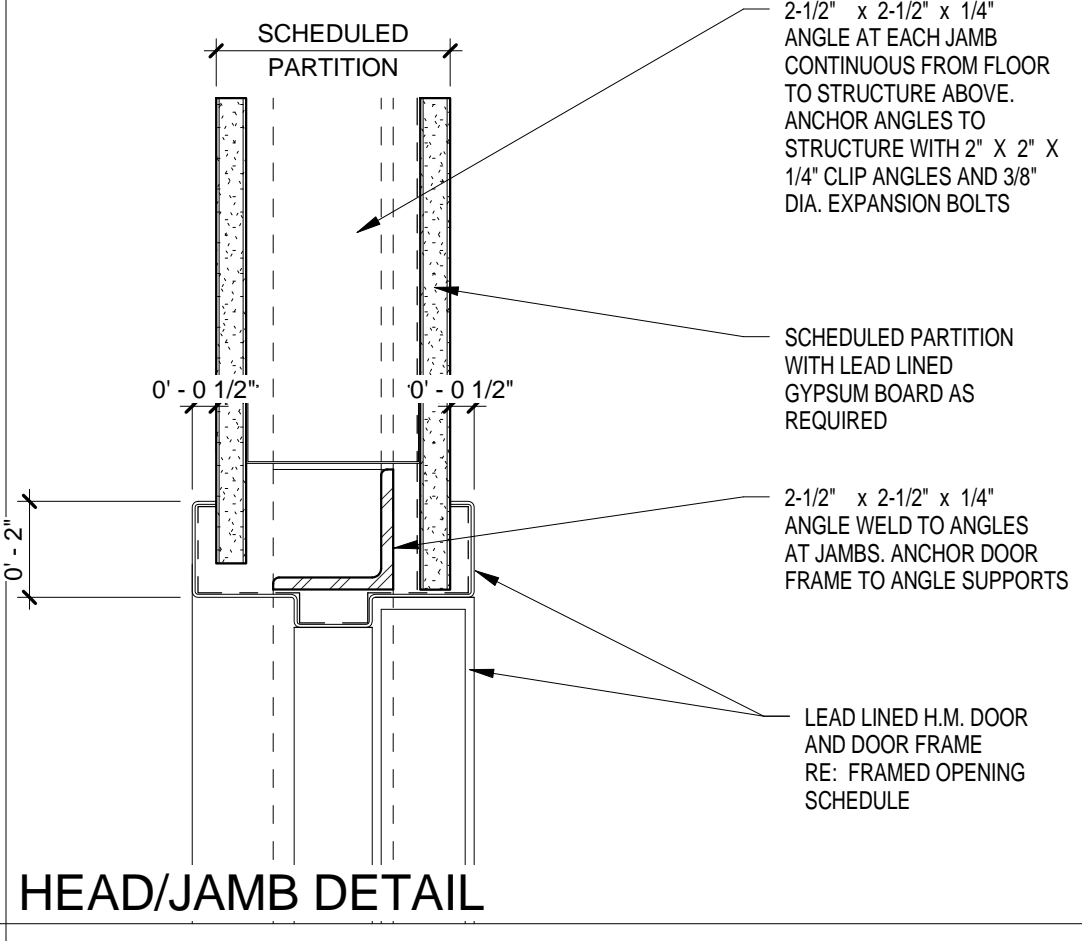

5 HEAD/JAMB DETAIL

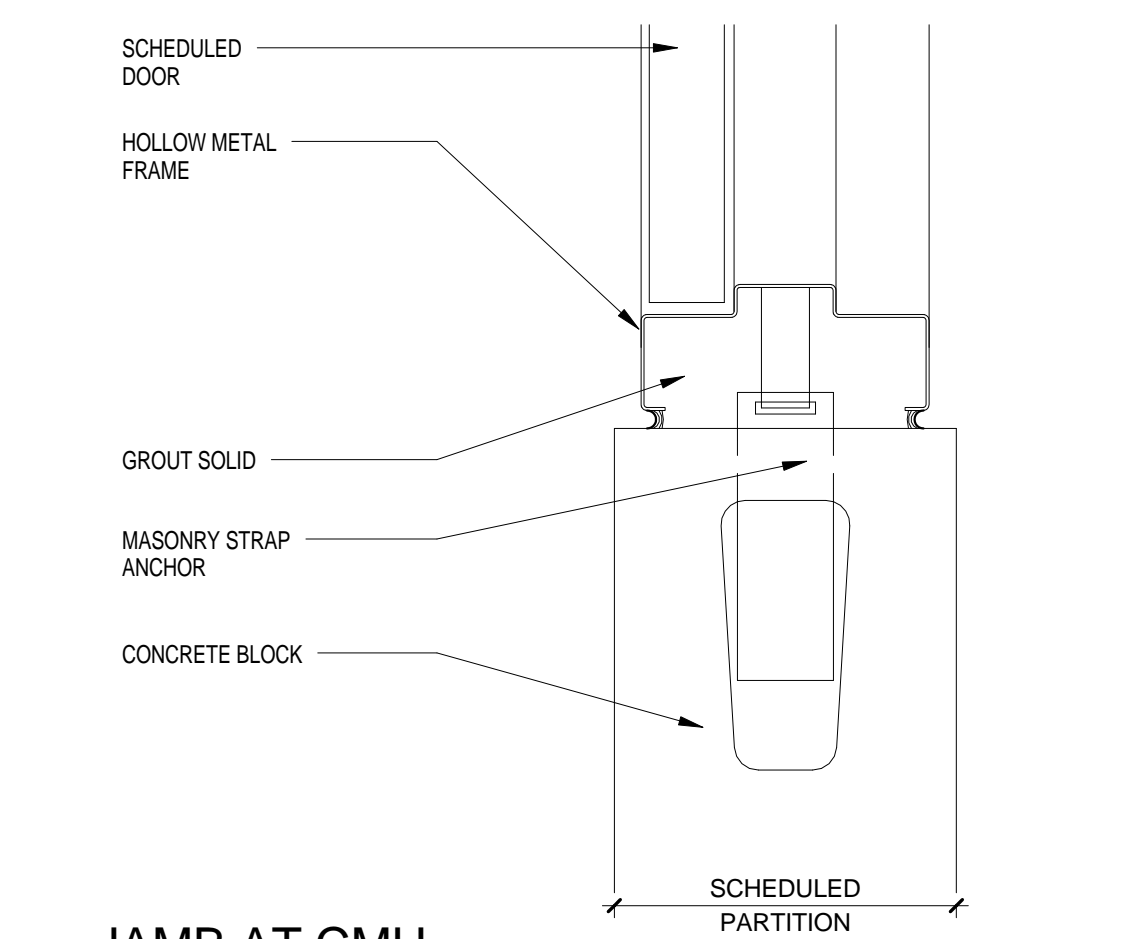

6 JAMB AT CMU

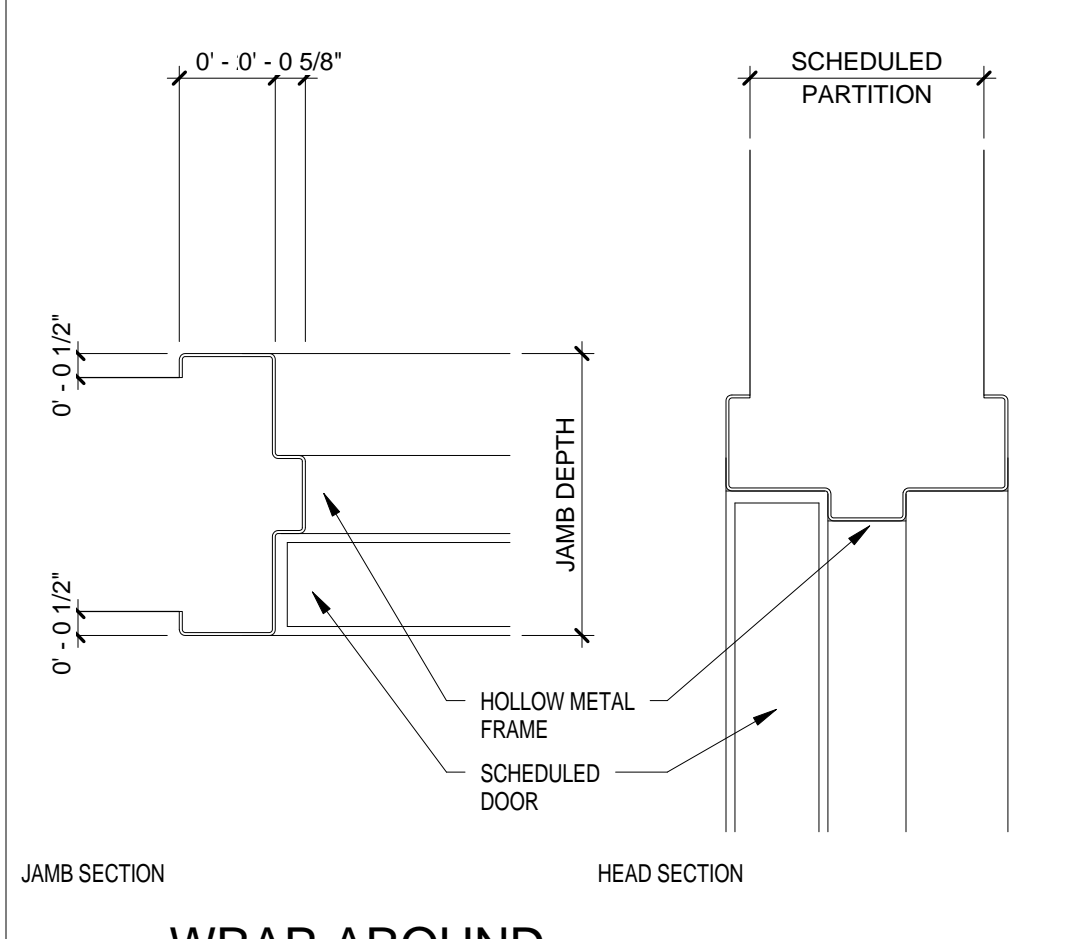

C2 WRAP-AROUND

GLASS TYPES

- IG#1 VISION - CLEAR
- IG#2 VISION - GRAY COLOR

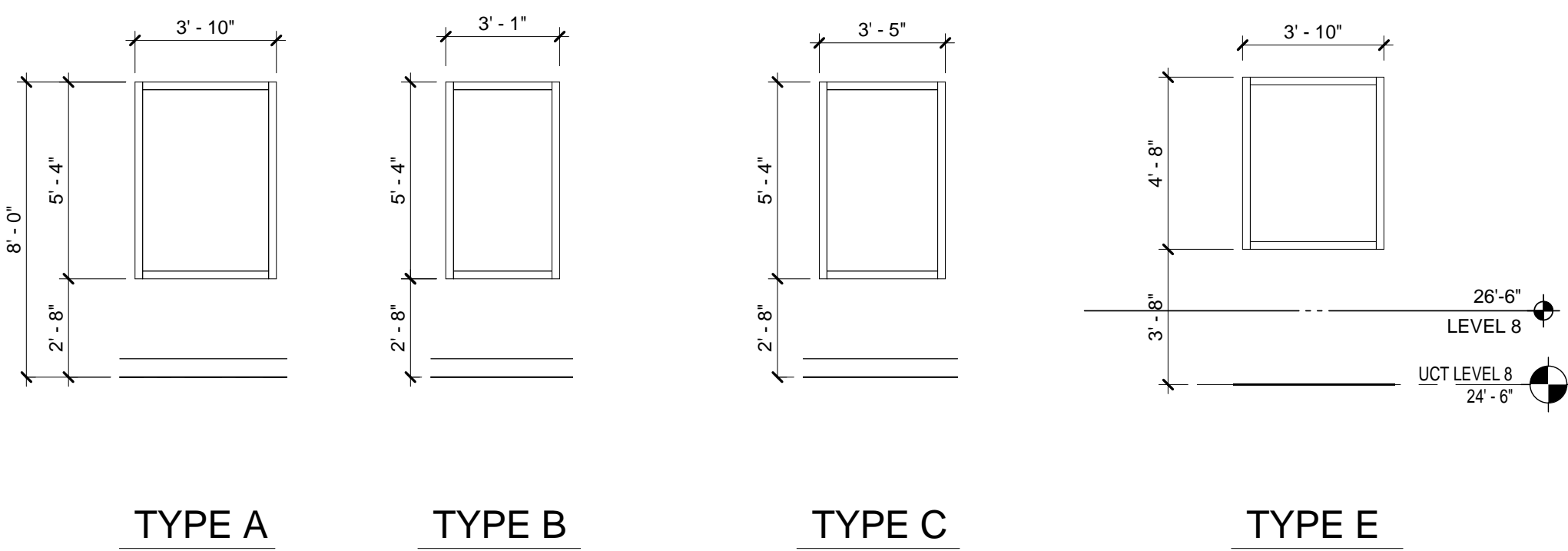

TYPE A TYPE B TYPE C TYPE E

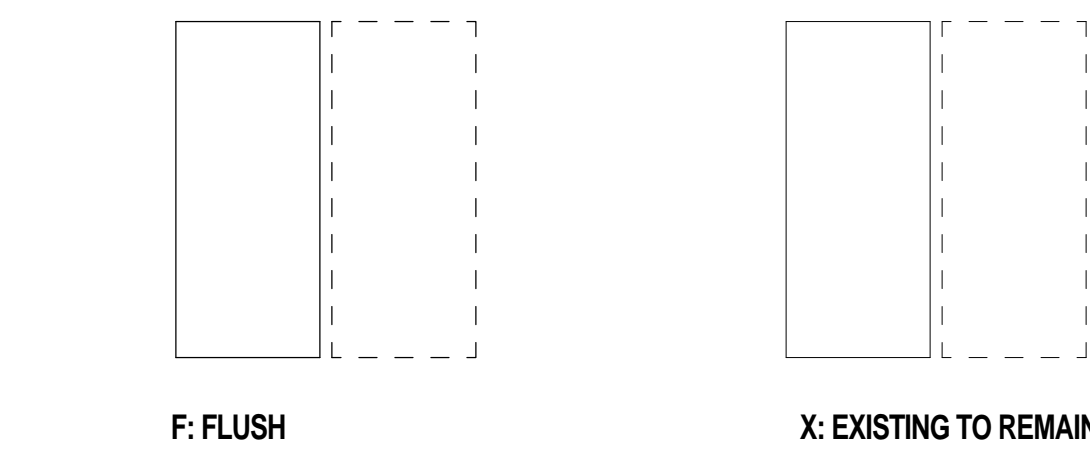

B3 DOOR TYPES
SCALE: 1/4" = 1'-0"

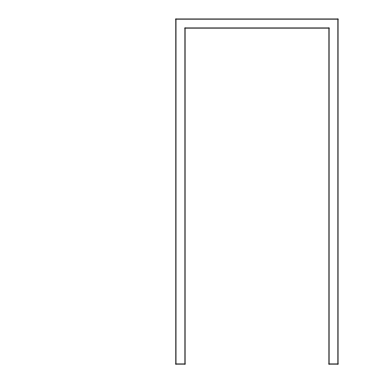

1 STD. WRAP AROUND
A3 FRAME TYPES
SCALE: 1/4" = 1'-0"

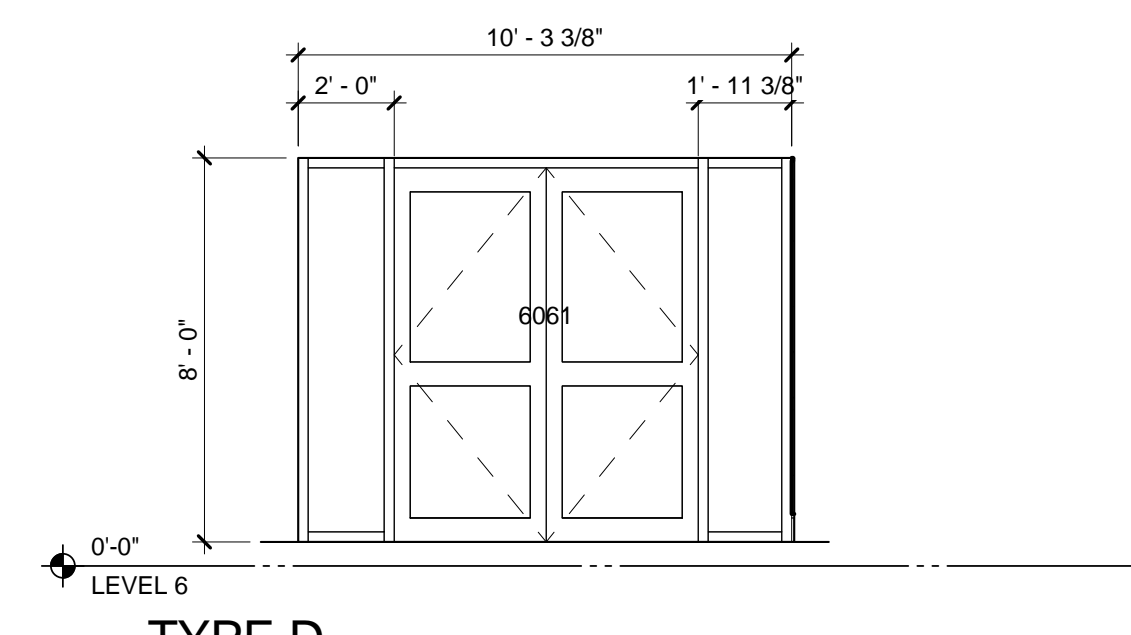

TYPE D

KEY PLAN

UCT
VERTICAL
EXPANSION

UTHealth
The University of Texas
Health Science Center at Houston

UTHSC-H UCT

7000 FANNIN
HOUSTON, TX 77030



DOOR, OPENINGS AND
FRAME TYPES

PHASE: 100% CD
DATE: 2016-11-15

PROJECT NO.
G15311-00

A601

Copyright © 2015 WHR Architects, Inc.